

THIS DRAWING IS UNPUBLISHED. RELEASED FOR PUBLICATION, 19  
 © COPYRIGHT 19 BY AMP INCORPORATED. ALL INTERNATIONAL RIGHTS RESERVED.

LOC AF	DIST 50	P	F	REVISIONS				
				ZONE	LTR	DESCRIPTION	DATE	APPD
					V	ADDED -5 PER 0G3A-0128-00	24FEB00	JR/PD

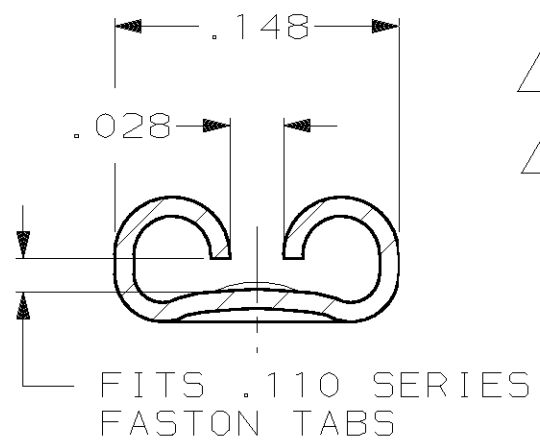

- 1 CONTINUOUS STRIP ON REELS
- 2 FEED TO BE .535±.005.
- 3 REVERSE REELING W/ PAPER INTERLEAVING
- 4 PRELIMINARY - NOT FOR PRODUCTION

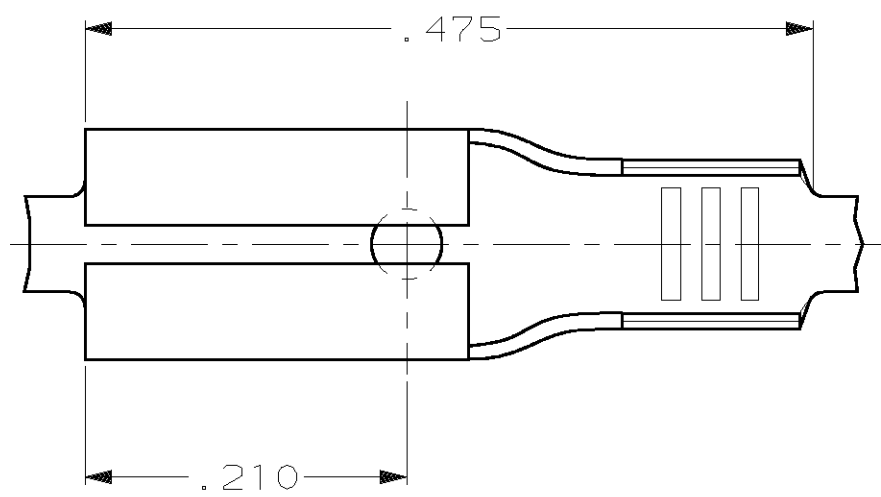
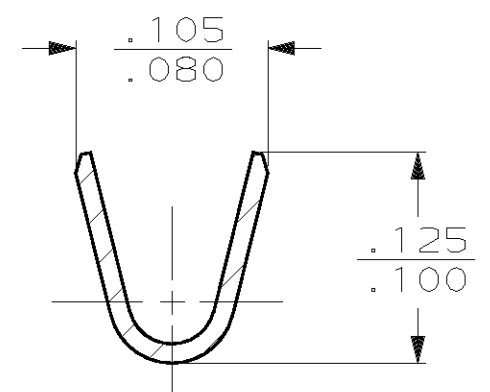
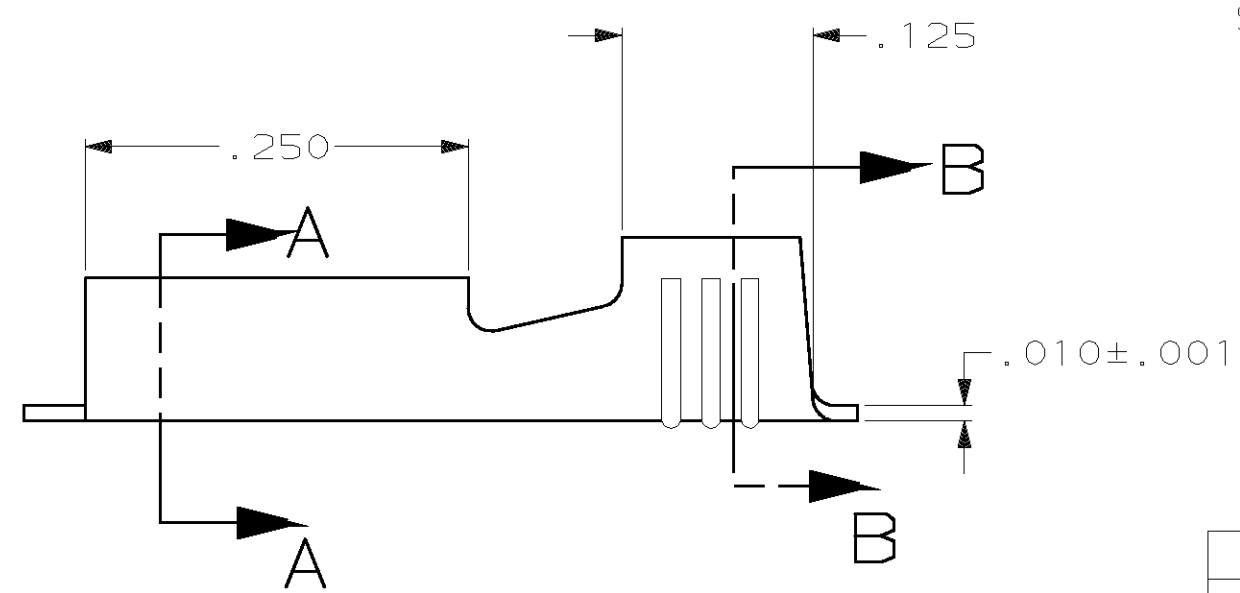

PRE-TIN			3 4 42399-5
-			42399-2
PRE-TIN	20-18 or (2) #20's	.020	42399-1
FINISH	WIRE SIZE	MATING TAB THK ±.001	PART NO
DO NOT SCALE PRINT. UNLESS SPECIFIED DIMENSIONS ARE IN INCHES. TOLERANCES ON: 2 PLC DEC ± - 3 PLC DEC ± .015 ANGLES ± -	DR 4/1/91 JR RUTH CHK 4/1/91 MS FEHER APPD 4/1/91 C MEYERS APPD 4/1/91 D REINER PRODUCT SPEC -	AMP AMP Incorporated Harrisburg, PA 17105-3608	
MATERIAL #4H BRASS	APPLICATION SPEC -	NAME RECEPTACLE, FASTON, .110 SERIES	
FINISH SEE TABLE	WEIGHT -	SIZE B	CAGE CODE 00779
		SCALE 8:1	DRAWING NO 42399
			SHEET 1 OF 1